



GLASSCRAFTERS INC.

GLASSCRAFTERS, INC.
193 Vetrans Blvd., Carlstadt, NJ 07072

1+ (888) 683-1362 (F) 1+(201) 525-1117
sales@glasscraftersinc.com

EPIC™ SERIES

Model Semi-Frameless Neo Angle Installation Instructions Model E-Neo

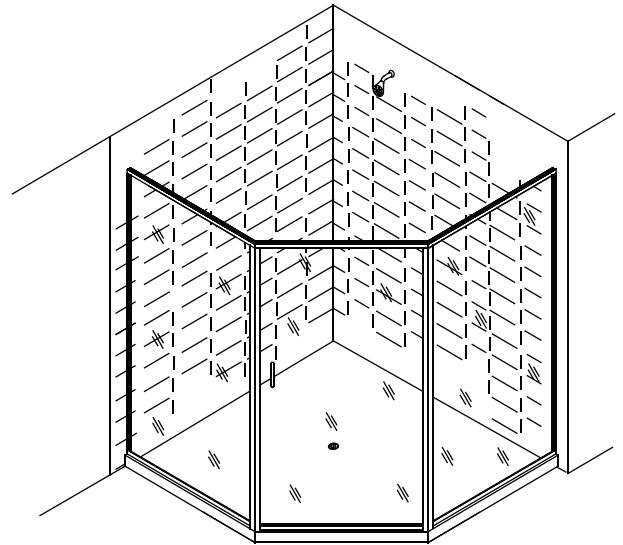
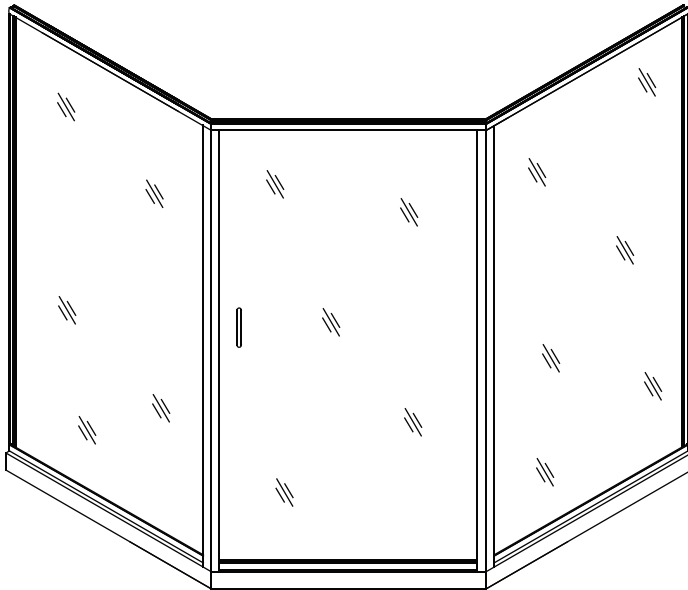

IF YOU NEED REPLACEMENT PARTS OR HAVE INSTALLATION QUESTIONS,
PLEASE CALL OUR CUSTOMER SERVICE REPRESENTATIVES.
INSTALLATIONS SHALL BE MADE ACCORDING TO MANUFACTURER'S INSTRUCTIONS AND DRAWINGS.
GLASSCRAFTERS RECOMMENDS THE INSTALLATION TO BE PERFORMED BY A TRAINED INSTALLER.

888-683-1362







READ INSTRUCTIONS BEFORE STARTING INSTALLATION

Item No.	Description	Qty	Item No.	Description	Qty
#1	Threshold	1	#11	1/2" Tek Screws	4
#2	Wall Jamb	2	#12	Header/T-hold Insert	2
#3	Anchors	6	#13	Strike Jamb	1
#4	8x1 1/2" Screws	6	#14	Vertical Glazing Vinyls	
#5	Setting Blocks	2	#15	Horizontal Glazing Vinyl	
#6	Bulb Seal	2	#16	Hinge Jamb	1
#7	135 Corner Post	2	#17	Deflector	1
#8	Header	1 (3 pcs)	#18	Clamp-on Magnet and pad	1
#9	8x7/16 Screws	12	#19	Hinge Stile	1
#10	Slide in Magnet	1	#20	D-Pull Handle	1

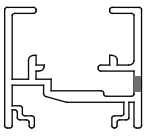
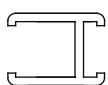
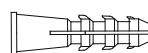
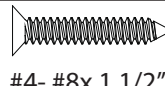
CAUTION: Risk of injury or product damage. Do not attempt to cut tempered glass.

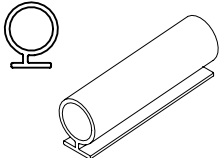
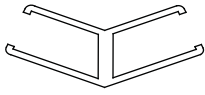
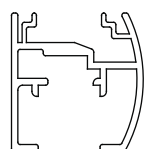
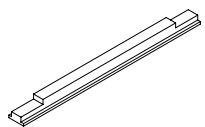
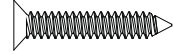
IMPORTANT! Children should be supervised at all times while in Tub/Shower Enclosure.

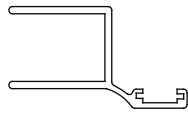
IMPORTANT! Never use Door Handle to support yourself. This is for towels or wash cloths only.

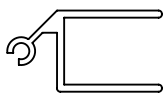
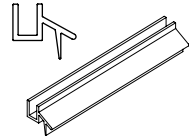
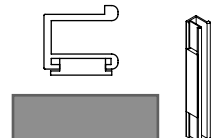
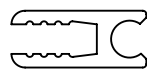
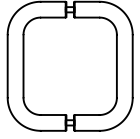
 #1- Threshold	 #2 -Wall Jamb	 #3- Anchors	 #4- #8x 1 1/2"  #9- #8x7/16"	 #5 Setting Blocks	 #6- Bulb Seal
 #7 135° Corner- Post	 #8 Header	 #10- Slide-in Magnet	 #11- 1/2" Tek Screws	 #12- Header/ T-Hold Inserts	 #13- Strike Jamb
 #14 Vertical Glazing Vinyl	 #15 Horizontal Glazing Vinyl	 #16- Hinge Jamb	 #17- Deflector	 #18- Clamp-on Metal Pad / rubber	 #19- Hinge Stile
 #20 - 6" D-pull					

Please Note:

* Parts #16, #19, #6, #10 and the Door Glass are pre-assembled in factory.

* Part #20 - Standard D-pull. Additional handles are available.

* Part # 18 - Included in package with wrap around black rubber pad.

* Please contact Customer Service with replacement parts requests. When ordering replacement parts, please specify the Model Number, Item Number & Part Description.

* Save Installation Instructions For Future Reference And In The Event You Need To Order A Replacement Part.

PLEASE STOP THE INSTALLATION AND CONFIRM WITH FACTORY IF THE ACTUAL NUMBER OR TYPE OF PARTS IS DIFFERENT.

Tools Required - For installation of Your Shower Enclosure:

- A** - Safety glasses.
- B** - Measuring tape.
- C** - Pencil.
- D** - Hacksaw (with 32 teeth per inch blade).
- E** - Miter Box or Square.
- E*** - Chop saw with carbide Tooth blade.

- F** - Level.
- G** - Electric Drill.
- H** - Center Punch
- I** - Drill bit, 1/8" (for installation on a fiberglass enclosures)

- I*** - Drill bit, 3/16" masonry (for installation on ceramic tiles or marble)
- J** - Drill Bit #29, for drilling screws #9 and #11.
- K** - Power screwdriver
- L** - #2 Phillips screwdriver

- M** - Caulking gun
- N** - Block of wood or Glazing block
- O** - Wooden shims
- P** - Silicone
- Q** - Masking Tape

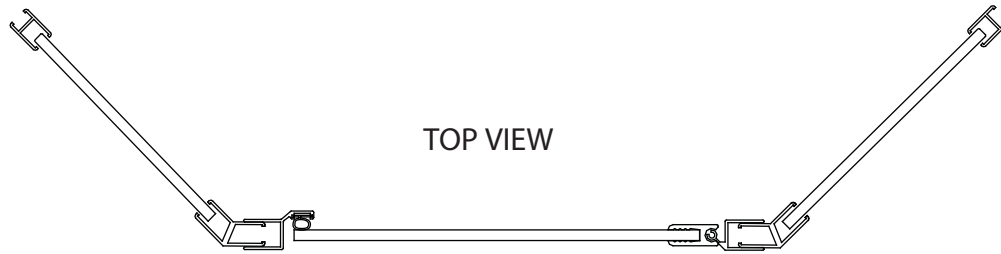

OUTSIDE OF ENCLOSURE

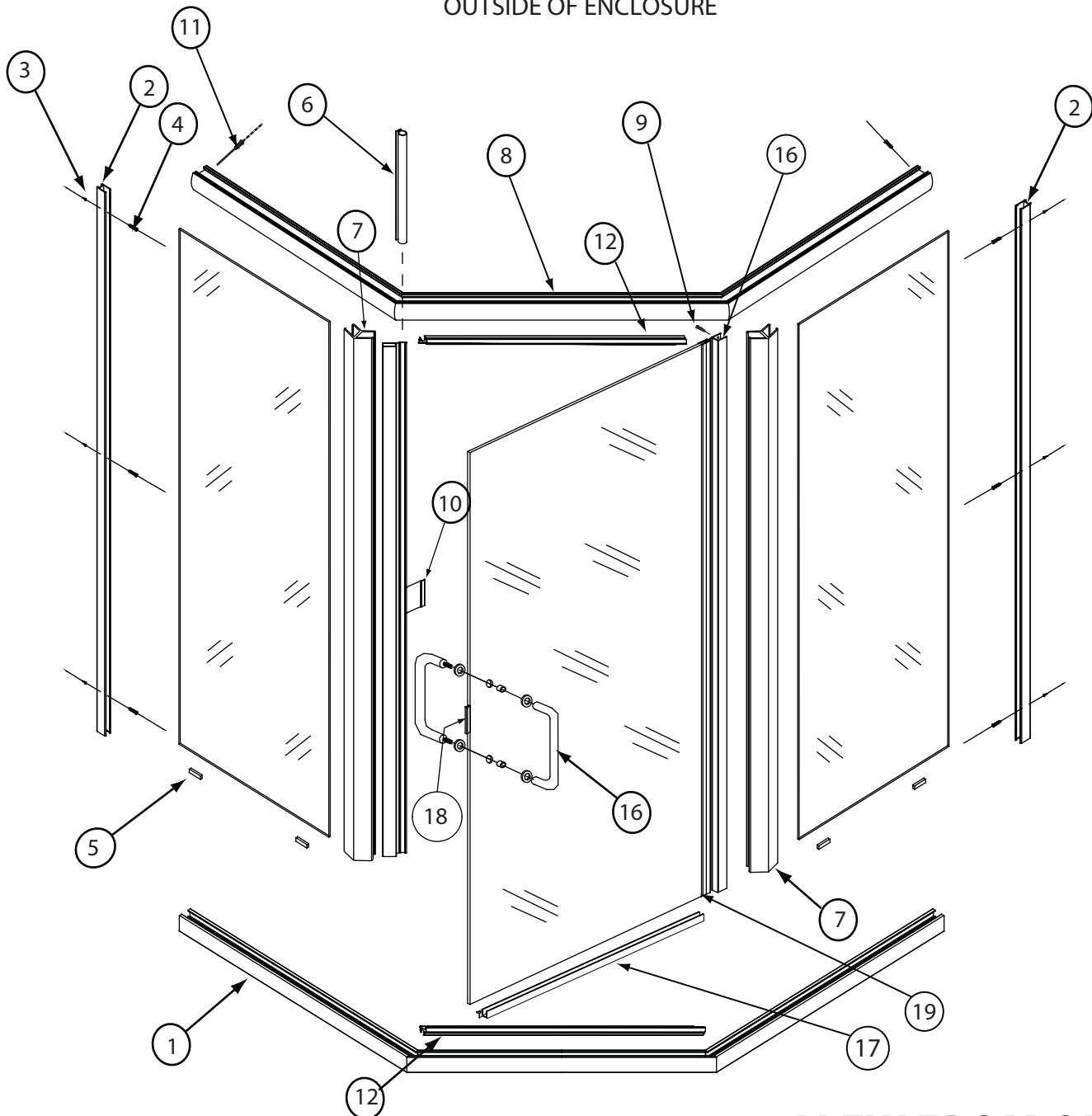

VIEW FROM OUTSIDE

Installation Instructions For GlassCrafters Semi-Frameless Neo-Angle

IMPORTANT: Read all instructions carefully and become familiar with all parts before installation.

Unpacking: Care should be taken unpacking your Shower Enclosure. Place the Glass Panels in an upright, Safe location to avoid damage. Never place glass directly on hard surface.

A Box cutter should not be used to open box.

Please remove all staples from the box prior to unpacking metal and glass.

Cleaning: Never use scouring powder, pads or sharp instruments on metal work or glass panels. We recommend the use of a squeegee after each shower to eliminate water spots on the inside of the glass panels.

An occasional wiping down of the glass panels and anodized aluminum parts with a mild detergent, diluted in water, is all that is needed to keep your Shower /Tub Enclosure looking brand new.

Please Note; this Shower Enclosure Door ONLY swings outward. Be sure to allow room for the door to open.

1

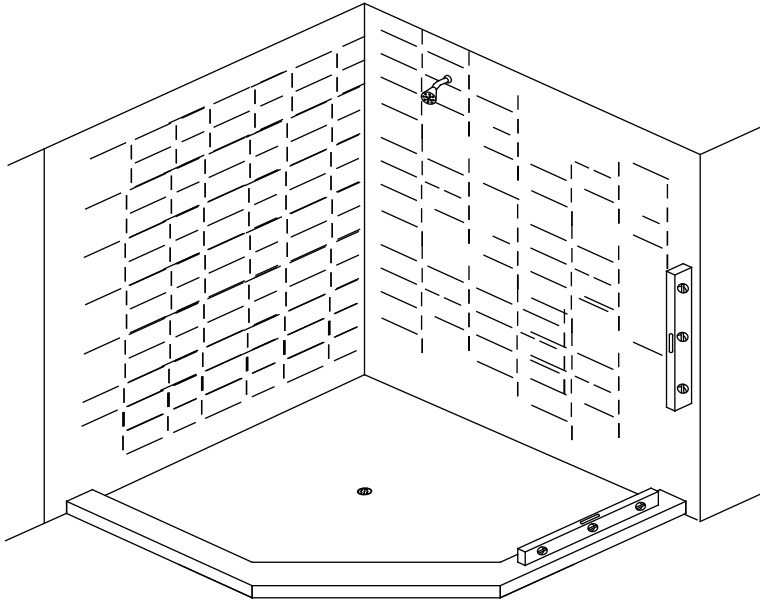

Sketch 1 A

Determine if your Shower Stall Enclosure Ledge is Level and Walls are Plum as shown in Sketch 1 A.

If they are out of level/Plumb by more than 1/4" STOP and call Customer Service.

A Base filler and/or Wall Jamb Filler is recommended for obtaining proper adjustment. Both are available through Customer Service.

2

Threshold (1) is cut to size at the factory.

Place Threshold #1 into position and temporarily secure it with masking tape as shown in **Sketch 2A**

If Threshold does not fit do not attempt to re-cut it. Contact Manufacturer for assistance.

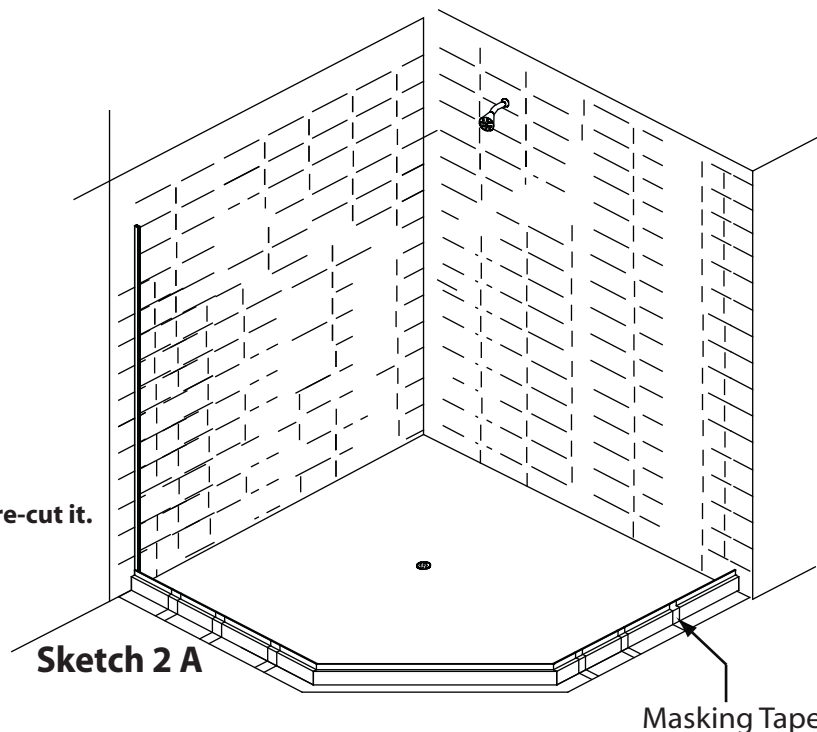

Sketch 2 A

Masking Tape

1/6/10

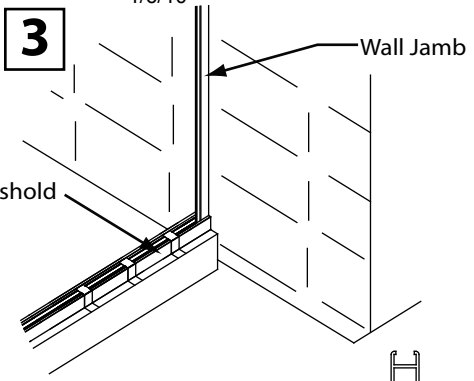

Carefully position the Wall Jamb into the Threshold as shown in **SKETCH 3A**. Be careful not to move the temporary position of the Base. Use a level to plumb the Wall Jamb and mark hole locations as shown in **SKETCH 3B**. Repeat this procedure with the Wall Channel on the opposite Wall.

Remove Wall Jambs and Threshold. Drill marked mounting holes as shown in **Sketch 3C**.

Insert wall anchors #3 as shown in **Sketch 3D**

Sketch 3 A

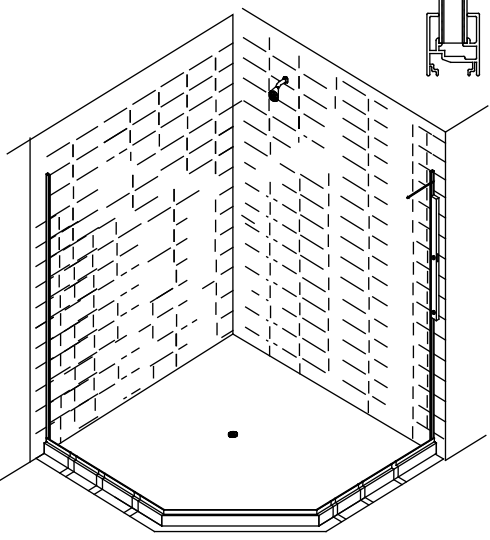

Sketch 3B

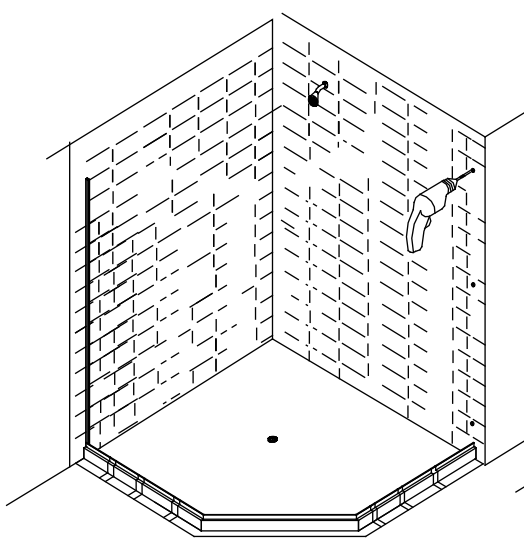

Sketch 3C

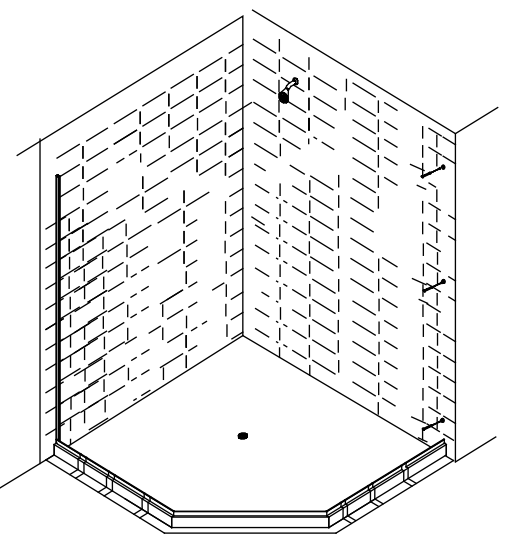

Sketch 3D

4 Flip Threshold over and apply Silicone Sealant to areas shown in **Sketch 4A and 4B**. Clean the Base from dust and tile Particles Place Threshold into position and temporarily secure it with masking tape. Apply a Layer of Silicone to Mitered Joints and each end of base where wall channels will be positioned to prevent water leakage. See **Sketch 4B**.

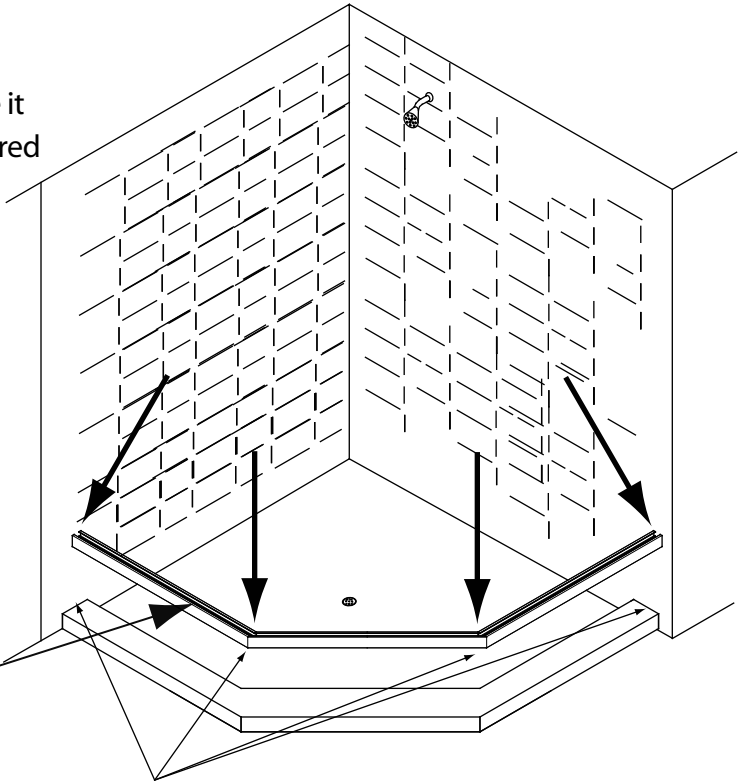

Sketch 4B

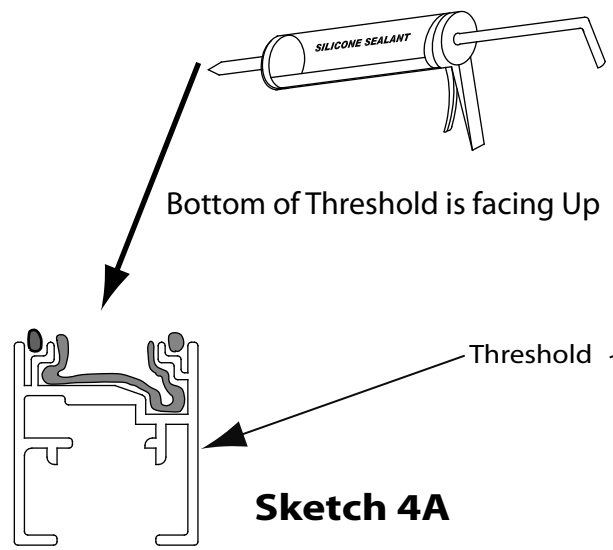

Sketch 4A

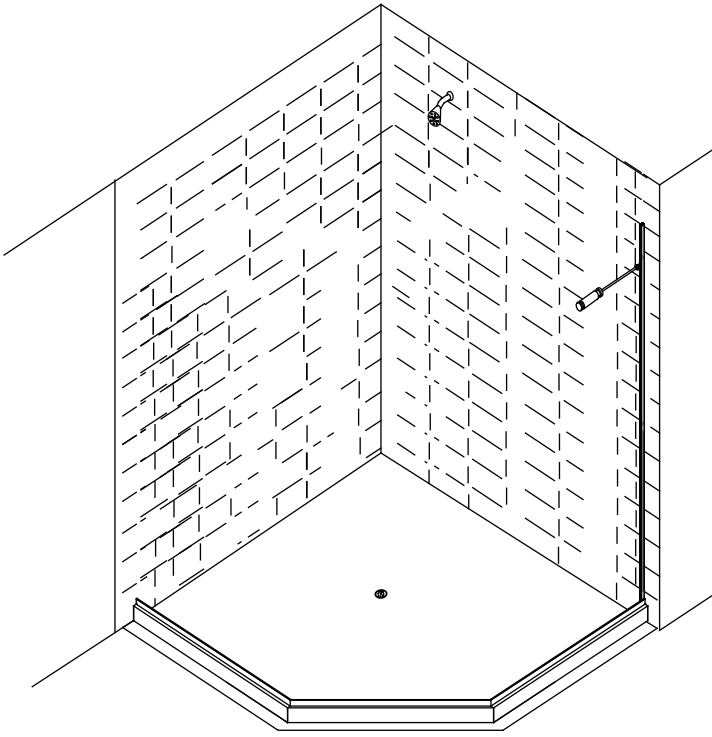
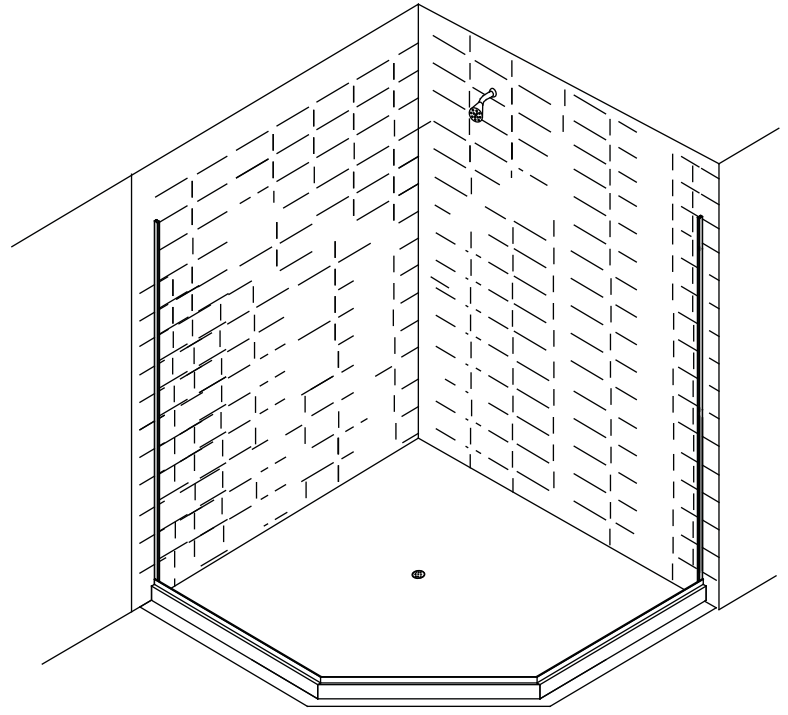
5Install Wall Jamb as shown in **Sketch 5 A** and **Sketch 5 B**.**Sketch 5A****Sketch 5B****6**

With Threshold # 1 and Wall jamb #2 installed, insert Setting Blocks #5 as shown in **Sketch 6A** with arch facing downward.

Place Glass Panels #6 and #7 into position as shown in **Sketch 6B**. **Be careful not to chip or strike glass edges.** Glass can brake if edges are not handled properly.

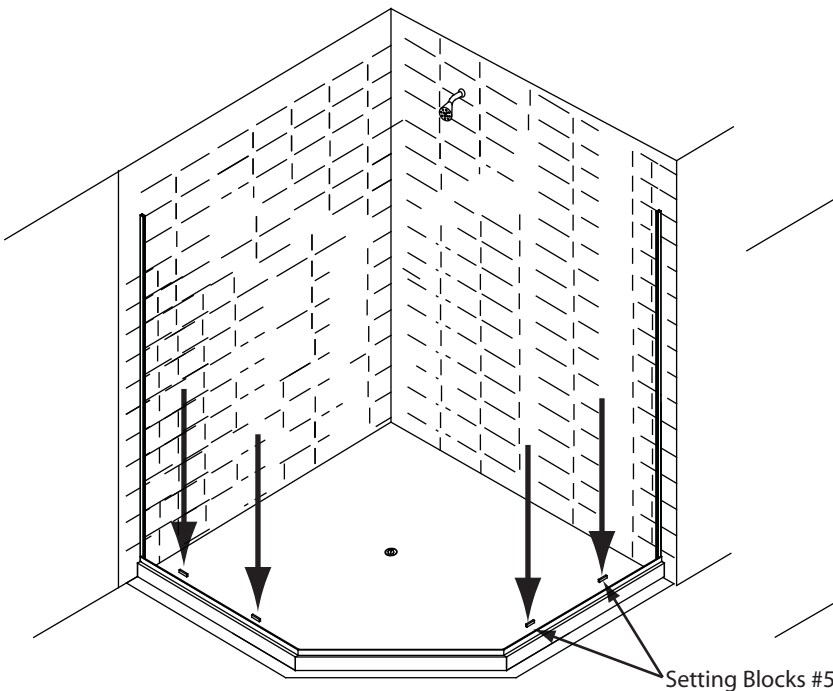
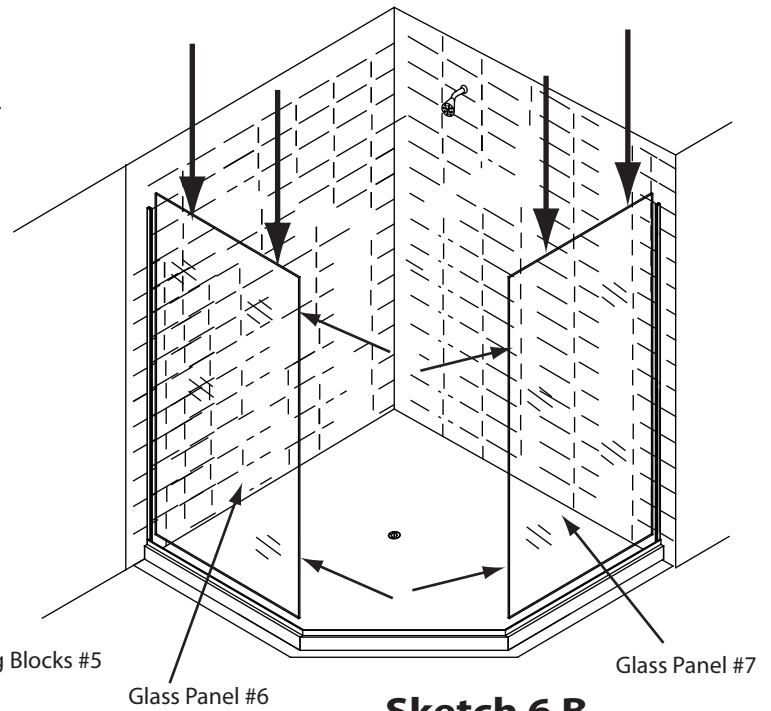
**Sketch 6 A****Sketch 6 B**

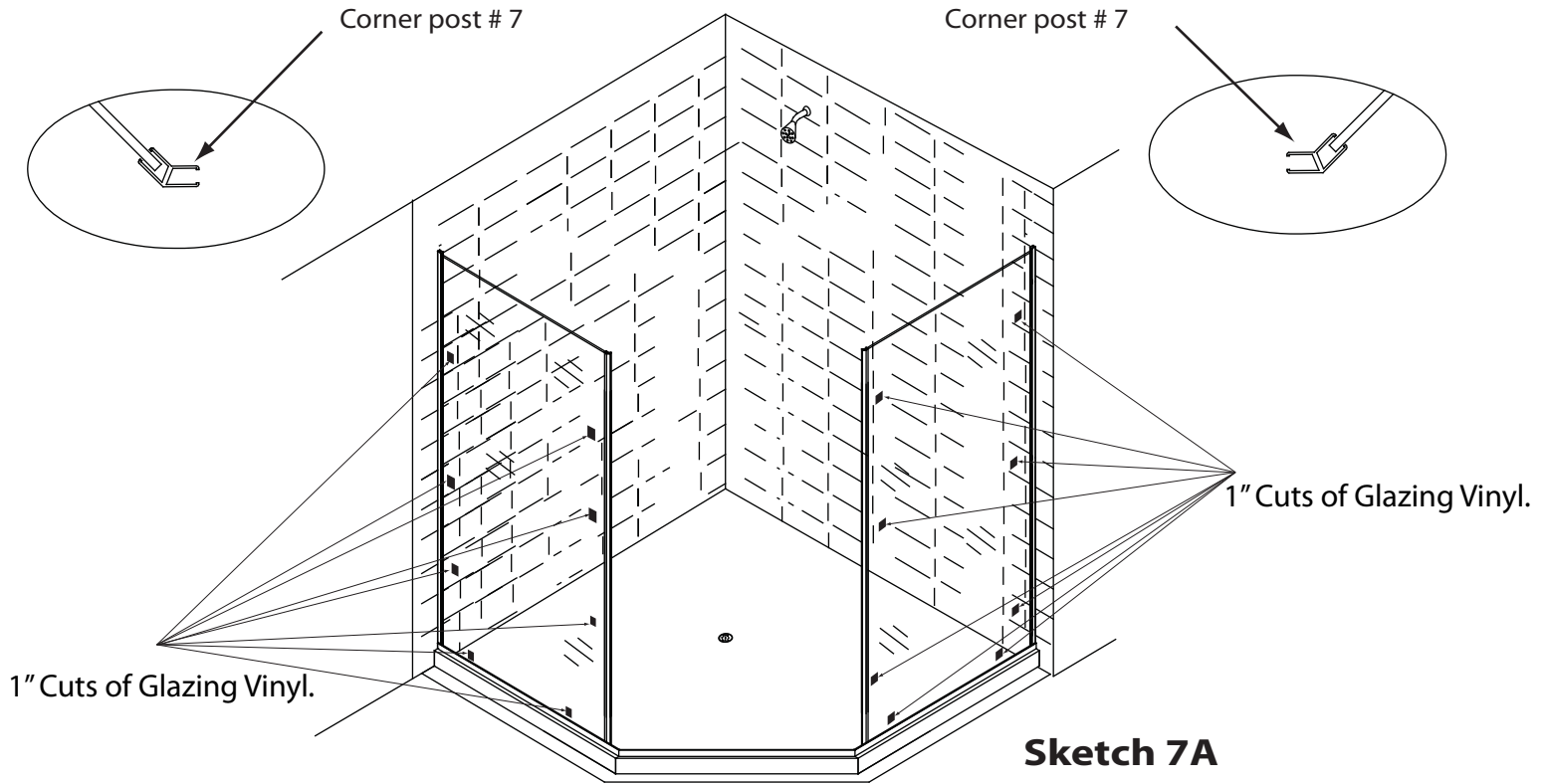
7Install Corner post # 7 as shown in **Sketch 7 A****Sketch 7A**

Cut (4) 1" pieces of horizontal glazing vinyl #15 and (12) 1" pieces of vertical vinyl #14

Tuck 1" cuts of vinyl into Threshold #1, Wall Jamb #2 and "H"- Post #7 to temporary secure glass panels in place.

See page 8, Sketch 9 for details.

This is a temporary setup. 1" cuts must be replaced later with continuous strips of glazing vinyl.

Make sure "H" Post #7 is plumb and space between "H" post and Wall Channel #2 is same on the bottom and on top.

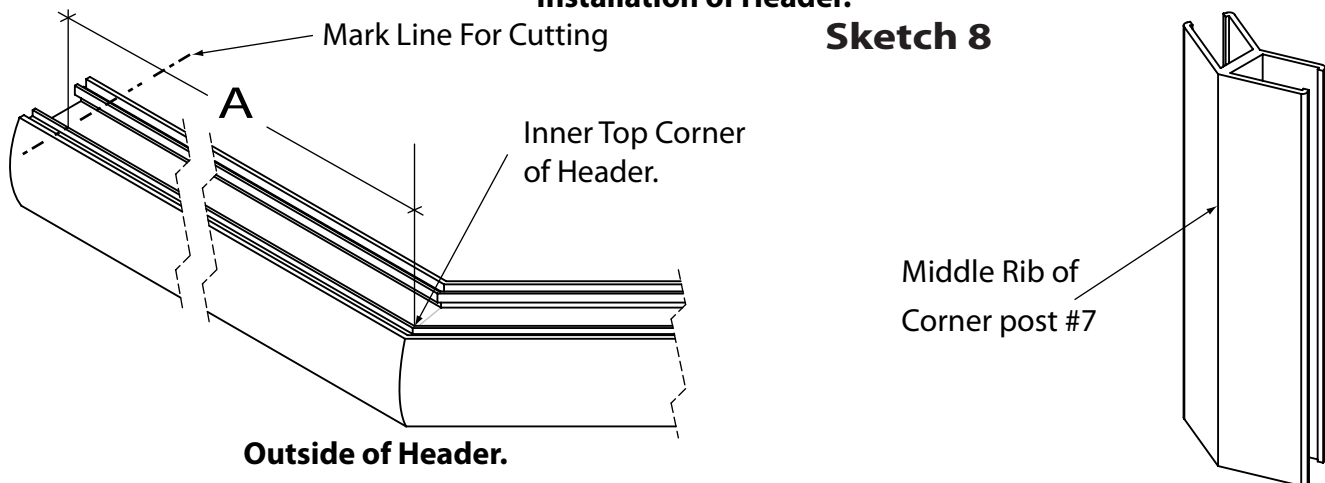
8**Installation of Header.****Sketch 8****Outside of Header.**

Measure the dimension "A" from the middle rib of left Corner post #7 to the left wall.

Mark size "A" on the header holding tape-measure on inner top corner of the header.

See **Sketch 8** for detail.

Cut the excess header.

Repeat this step for right side.

9

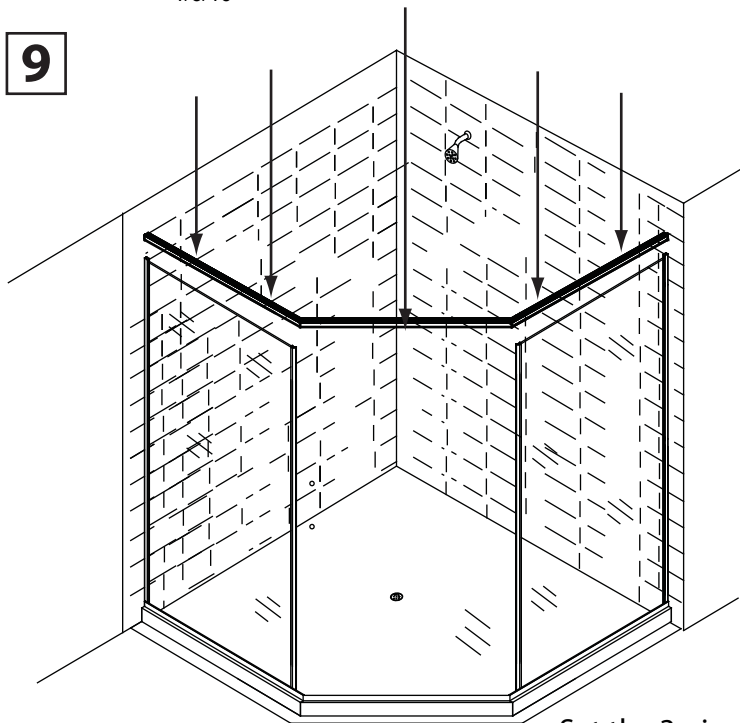

Sketch 9

Set the 3 piece Header #8 over the glass panels and metal extrusions. Make sure Wall Jamb #2 and Corner Posts # 7 penetrate into Header #8. Secure the header with few strips of masking tape, later to be replaced by screws #11.

10

Place wooden shims flat on Threshold #1. With Hinge Jamb # 16 in open position, slide Hinge Jamb #16 over Corner Post #7, close the door and set glass on wooden shims. (**Sketch 10 and 10B**). Make sure that there is sufficient space between vertical extrusions for glass to fit. Secure the door position on Corner post # 7. Slide Strike Jamb #13 over opposite Corner post #7. Adjust the width of the front opening by moving Hinge Jamb #16 and Strike Jamb #13 left and right. Make sure Door will swing freely without hitting any extrusion.

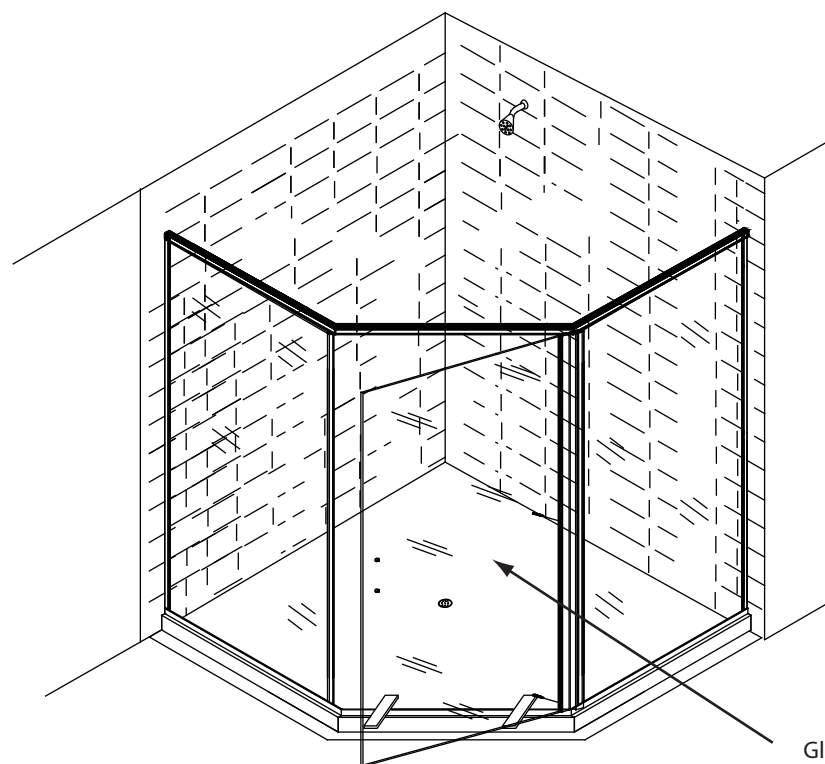

Sketch 10

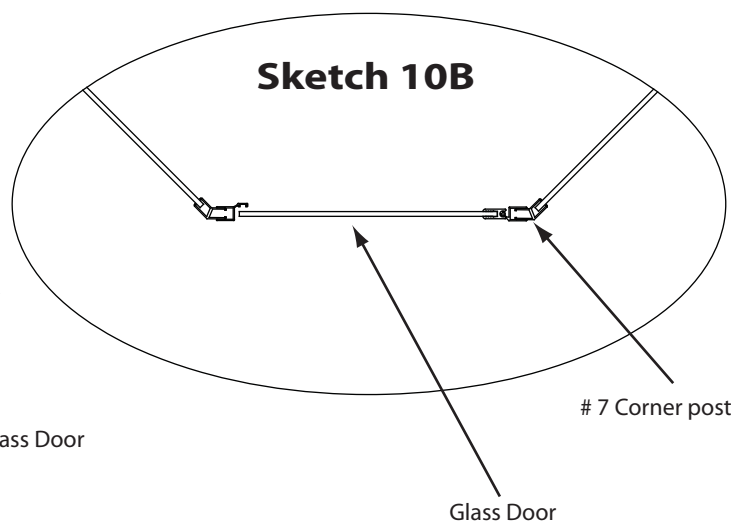

Sketch 10B

Glass Door

7 Corner post

Glass Door

11

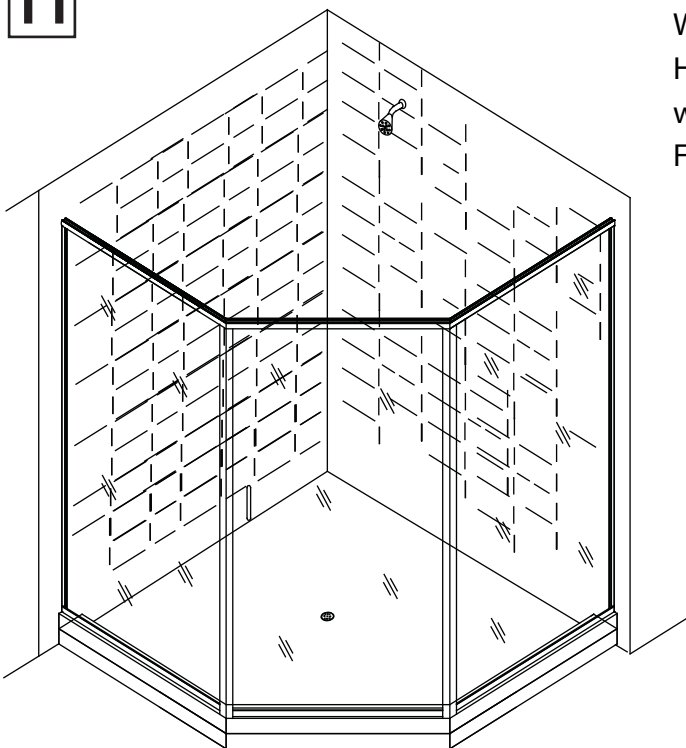

Sketch 11

With correct adjustments made, secure Strike Jamb #13, Hinge Jamb# 16, Wall Channels#2 and Corner Posts # 7 with screws # 9 . Secure Header with screws #11. For holes use drill bit #29.

Side Panel, Strike Jamb and Header are not shown for Clarity

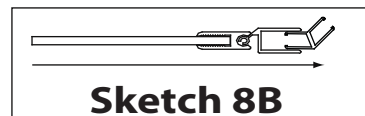

Sketch 8B

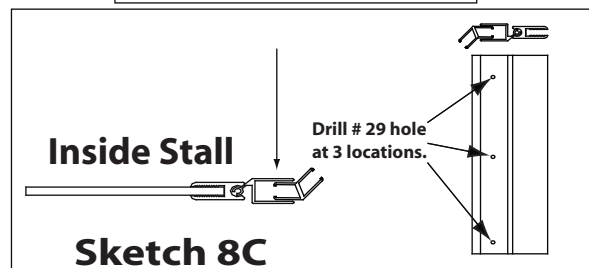

Sketch 8C

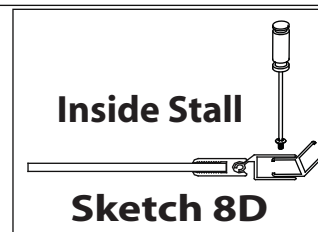

Inside Stall

Sketch 8D

12

Remove Temporary 1" cuts of Glazing Vinyls. Insert Horizontal Vinyl# 15 and vertical Vinyl # 14 as shown in **Sketch 12A and 12B.**

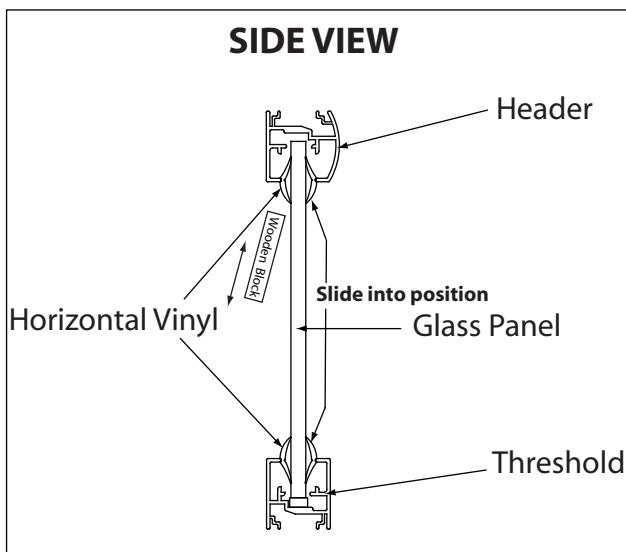

Sketch 12A

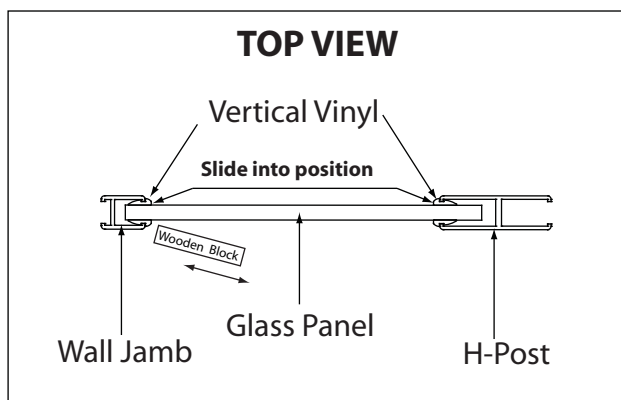

Sketch 12B

NOTE: A light spray of Glass Cleaner on the glass will help the vinyl slide into position. Flat square block of wood can be used to tap in vinyl.



3"x 5" Wooden block

13

Install D-Handle And #9 Clamp-On Metal Pad.
 Wrap Rubber Pad around the edge of Door Glass.
 Positioned In The Middle Of Handle. Gently tap on #18 Clamp-on Metal Pad to Door Glass
 Re-Adjust The Height of #10 Slide-In Magnet By Cutting #6 Bulb Seal.

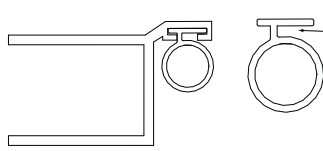
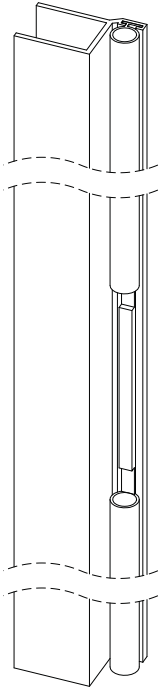

Wide side
toward door

Sketch 13B

Position magnet #10 In the middle of Strike Jamb #13.
 Measure the distance from magnet to top of Strike Jamb
 and from Bottom of Magnet#10 to bottom of Strike Jamb #13.
 Cut the Bulb Vinyls #6 to size. Slide Bottom Piece of
 Bulb vinyl #6 into Strike Jamb #13 first, followed by
 Magnet #10 and the top Piece of Bulb Vinyl #6.
 Please note that off set on Bulb Vinyl must be directed
 toward the door. See **SKETCH 13B** for details.

Sketch 13A

**Note: Take care when placing
Clamp on Door Magnet.**

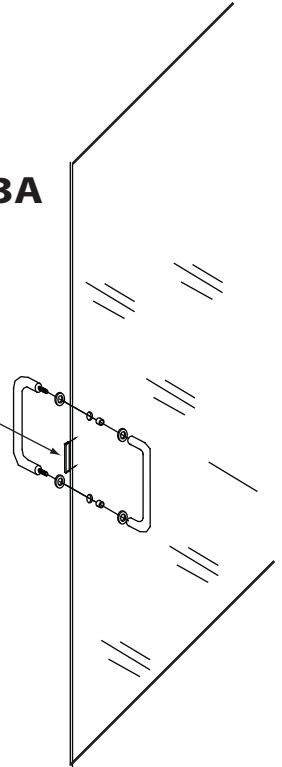

14

Header and Threshold Inserts.

With door glass in open position measure from Strike Jamb#13
 to Hinge Jamb #16 as shown on **Sketch 14A (Size A)**.

Cut Inserts#12 to size. Insert one into Header#8 and Threshold#1.

See **Sketch14B** for details. Insert will snap into position when pushed with a slight angle.

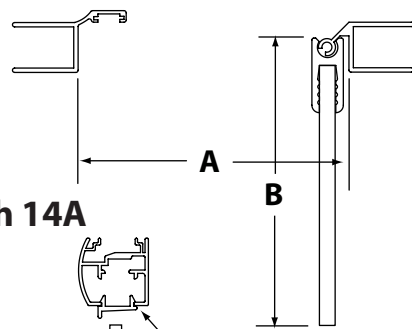

A
B

Sketch 14A

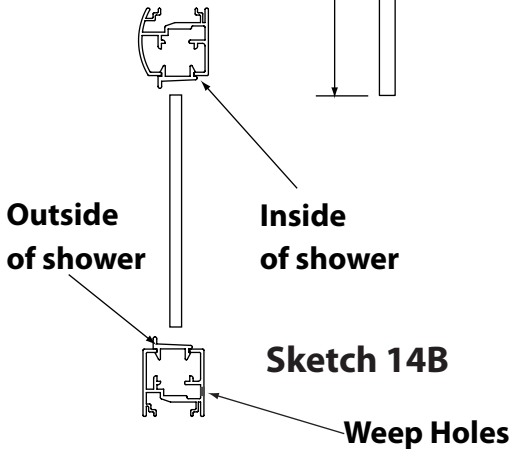

Sketch 14B

Deflector.

Measure from the Hinge Stile #19 to the edge of the door glass
Sketch 14A (Size B). Cut Deflector#17 to size. Notch Deflector#17 to fit
 around the extrusions.

Slide Deflector #17 on the Bottom of the door as shown in **Sketch #14C**.

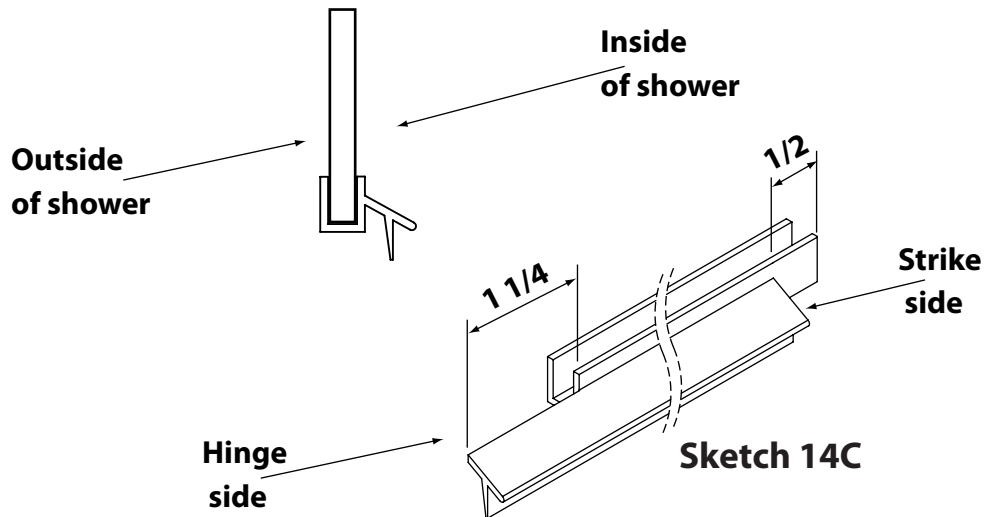

Sketch 14C

15

It is essential that Silicone Sealant be applied to complete perimeter inside and outside as shown in **Sketch 15**. When applying silicone Sealant to threshold, it is important not to cover WEEP HOLES with Silicone Sealant to ensure proper drainage. Proper application of silicone will prevent Water Leakage.

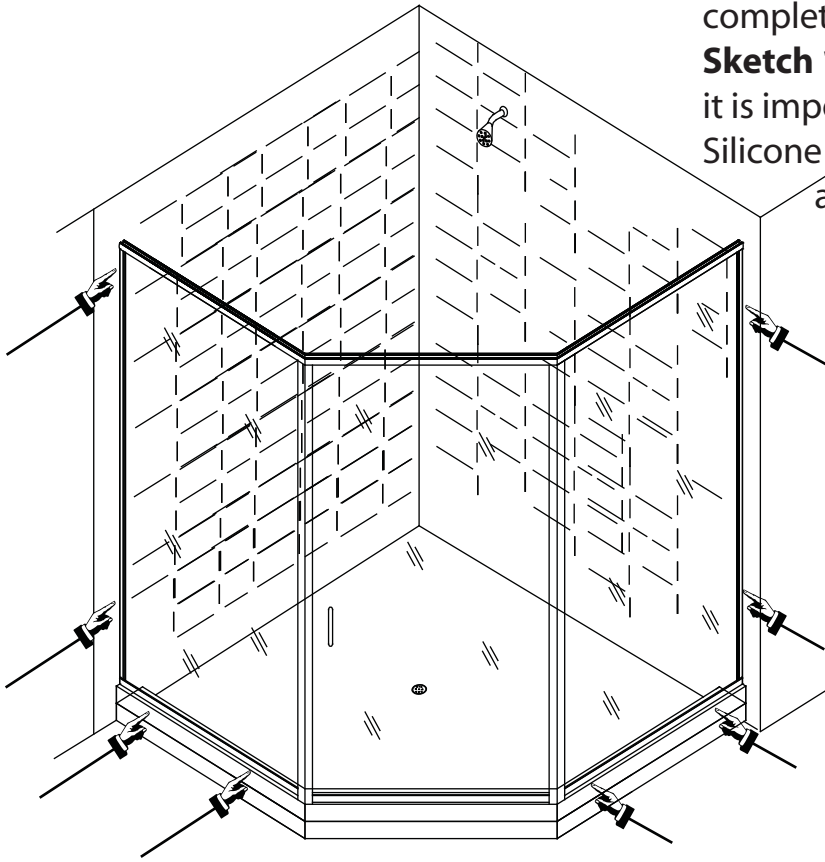
**Sketch 15**

Please note that after applying Silicone Sealant, the unit must not be used for 24 hours to allow the Silicone Sealant to set properly.